



Pretty
Plastic

building from waste

info@prettyplastic.nl
www.prettyplastic.nl
@we_are_prettyplastic

SECOND HIGH INSTALLATION MANUAL

March 2024

INSTALLATION MANUAL

PRODUCT NAME SECOND HIGH

TECHNICAL DATA

HEIGHT	294mm
WIDTH	294mm
THICKNESS	67mm

NUMBER OF TILES PER M ²	11.1
WEIGHT PER TILE	1.2kg
WEIGHT PER M ²	13.1kg

MATERIAL	recycled Polyvinylchlorid (PVC)
----------	---------------------------------

FLAMMABILITY (EN 13501-1:2018)	B-s3, d0
--------------------------------	----------

PRODUCTION TOLERANCES	+/-2%
-----------------------	-------

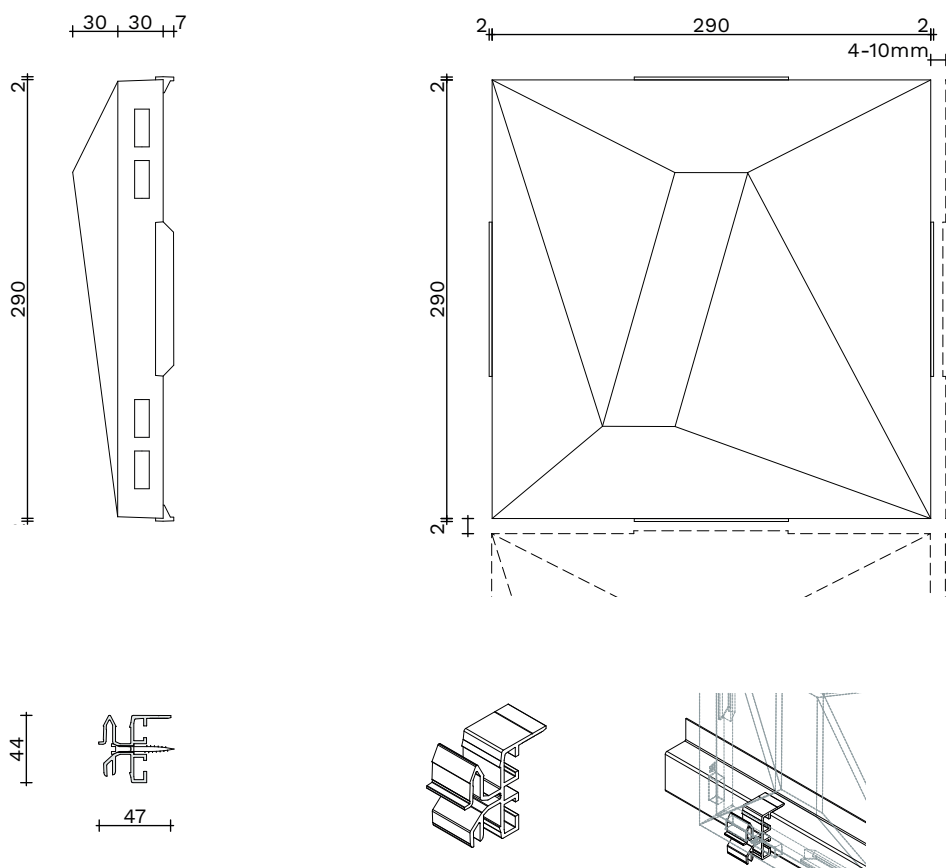

Recommended Mounting Bracket

INSTALLATION MANUAL



PRODUCT NAME SECOND HIGH

PRODUCT

Pretty Plastic tiles are utilized in ventilated facades, catering to both renovation projects and newly constructed facades.

PROCESSING

Pretty Plastic can be cut or drilled without producing any splinters. Tiles can be cut using a jigsaw, circular saw, or handsaw. Collect sawing waste and cutting losses separately to prevent them from being blown away. Make sure to manage these waste materials properly.

APPLICATION

- Pretty Plastic Second High tiles are suitable for prefab facade systems but can be installed on-site.
- Pretty Plastic tiles will be delivered with custom mounting brackets.
- It's important to note that the structural engineer holds the final responsibility for ensuring the accurate installation and application of the tiles.

PAINTING

Please note that Pretty Plastic tiles are not intended for painting.

MAINTENANCE

Pretty Plastic is maintenance-free and can be cleaned using household cleaning products.

INSTALLATION

Pretty Plastic tiles should be attached to a structure of aluminium omega-profiles of 40mm-25mm. We recommend using our specially developed mounting brackets to ensure a solid installation.

Secure each tile using two mountain brackets. Each bracket should be fastened with a single screw. Depending on the building's height and the local wind load, dedicated wind load studies need to be conducted. Refer to our technical guide for detailed information.

We recommend using WOODIES® Cladding screws, stainless steel 410, black reduced countersunk head, with TX recess, partial thread, or an equivalent product suitable for the underlying wall structure. For the bracket to function properly, the screw head should have an angle of 60 degrees instead of 90.

- Install horizontal omega-profiles with a 300 mm spacing. If necessary, utilize vertical substructure to establish a ventilated cavity.
- Secure each tile using two screws, depending on the building's height and the local wind load according to NEN-EN 1991-1-4. Check our technical guide for detailed information.
- Maintain a 10 mm seam for a center-to-center distance of 300 mm.
- For corner ends and window frame connections, refer to the proposed detail drawings for various possible solutions.

INSTALLATION MANUAL

PRODUCT NAME SECOND HIGH

TILE PATTERN ALUMINIUM STRUCTURE

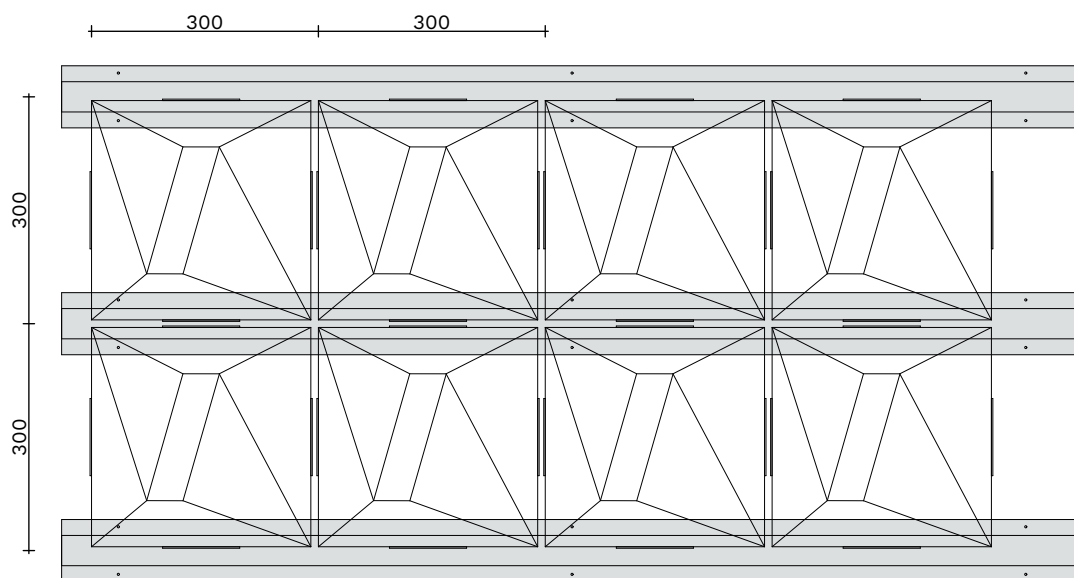

- for instructions on the aluminum structure, see next pages

INSTALLATION MANUAL

PRODUCT NAME SECOND HIGH

ALUMINIUM STRUCTURE

STEP 1

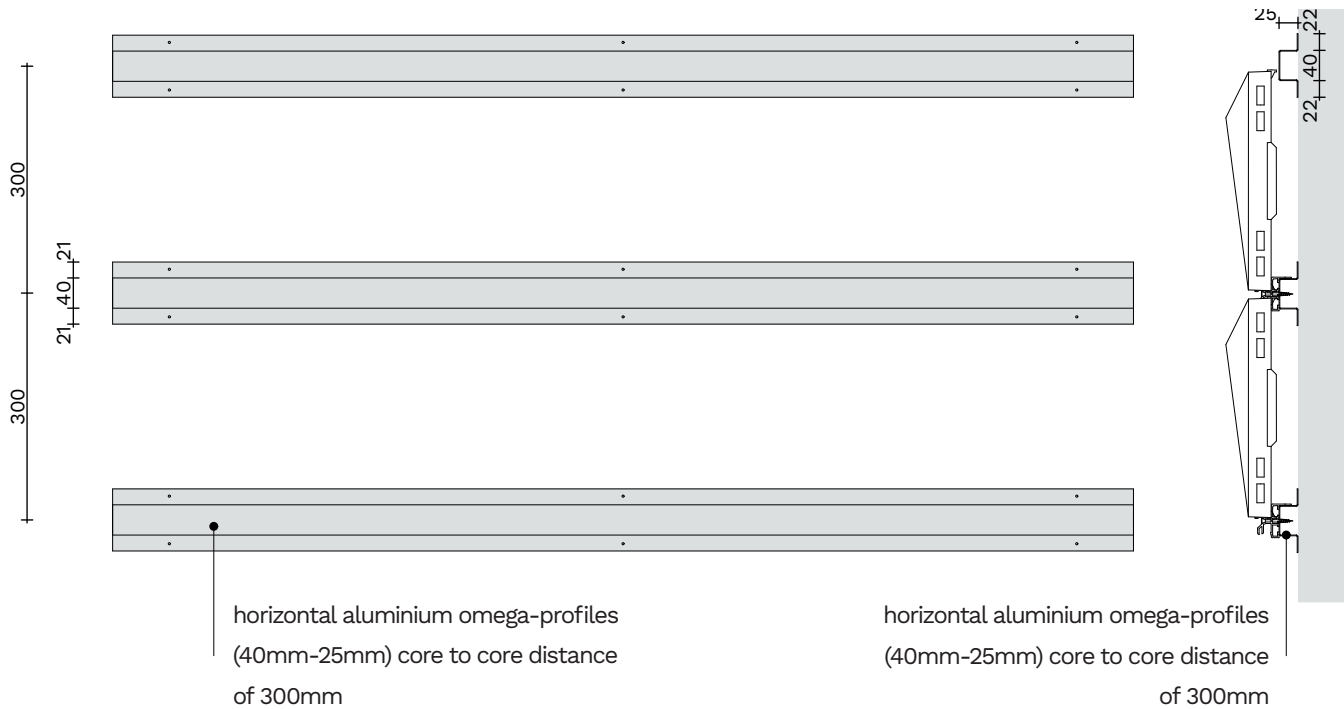

1. Construct an aluminium framework in front of the insulated wall.

STEP 2

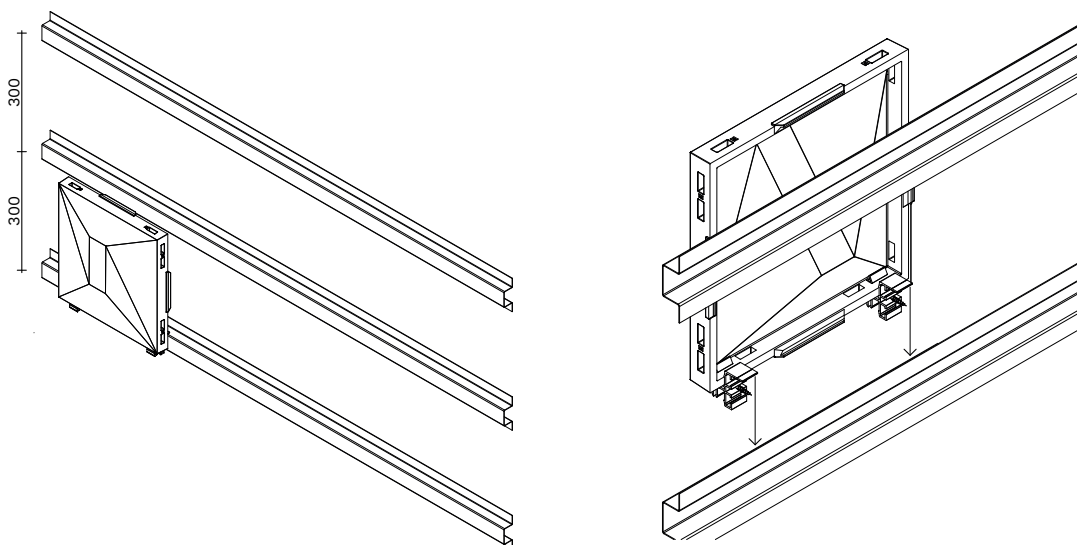

2. Start from a bottom corner, place a tile with the brackets in the recesses at the bottom, hang it on the omega-profile and secure it with two screws at each bracket.

INSTALLATION MANUAL

PRODUCT NAME SECOND HIGH

ALUMINIUM STRUCTURE

STEP 3

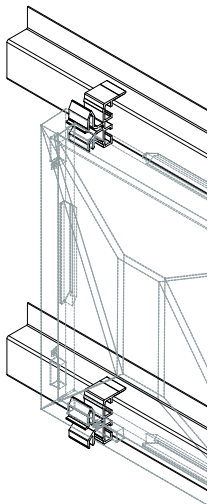
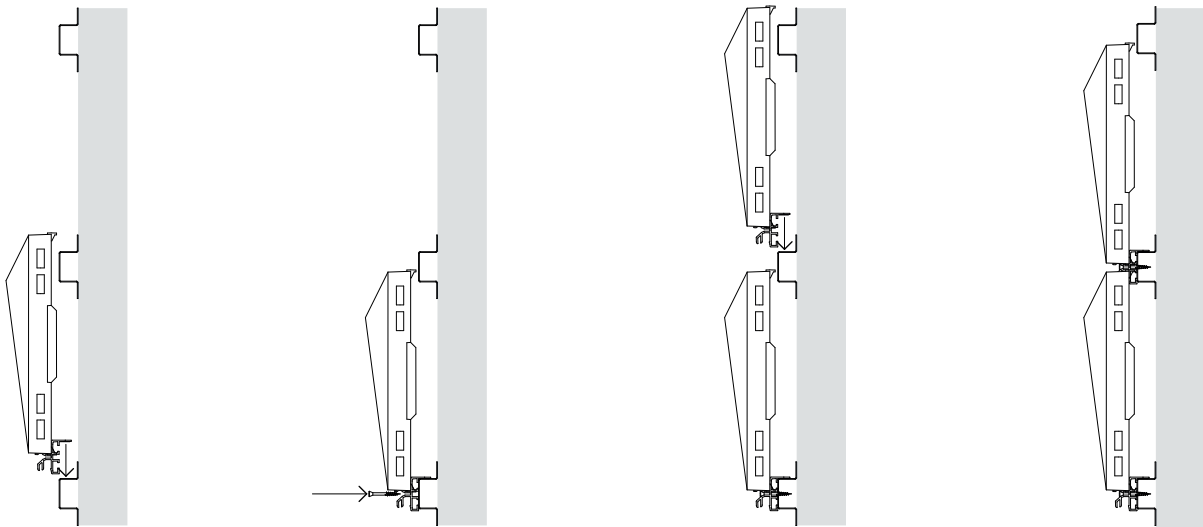

mounting principles for
aluminum structures

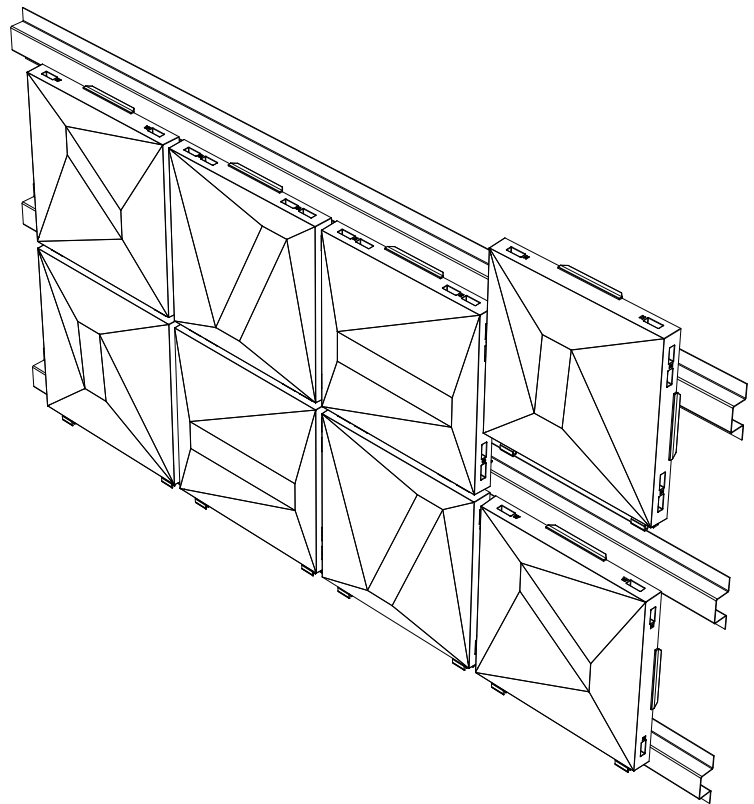

3. After finishing with the first tile, move to the next. This can either be the tile to the left or right of the first one or the one above. Place a tile above with the brackets in the recesses at the bottom, and position the bottom part of the bracket in the top recesses of the tiles below. Secure it with two screws.

INSTALLATION MANUAL

PRODUCT NAME SECOND HIGH

REMOVING TILES

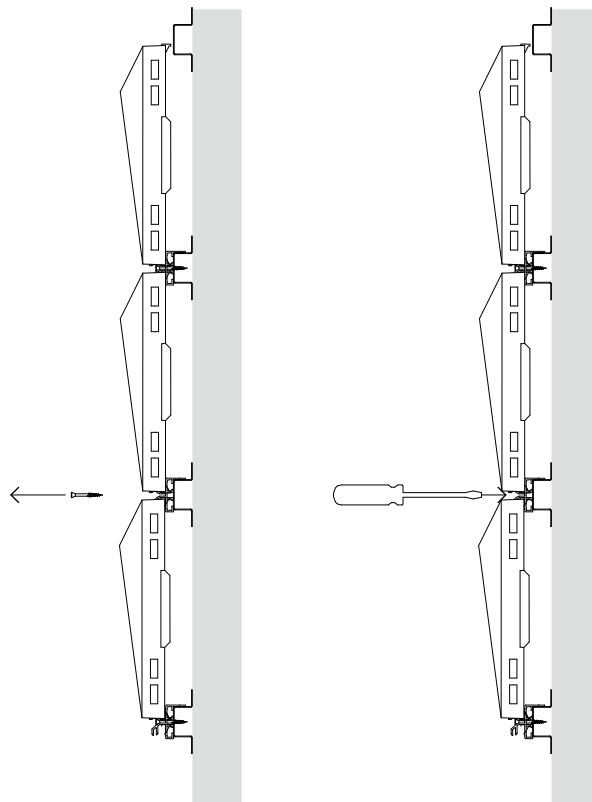

If needed, tiles can be removed using the following steps:

1. Unscrew the bracket.
2. Push the bracket with a small flat screwdriver.
3. The bracket will distort and can be removed, allowing the tile to come loose.

INSTALLATION MANUAL

PRODUCT NAME SECOND HIGH

DESIGN SUGGESTIONS

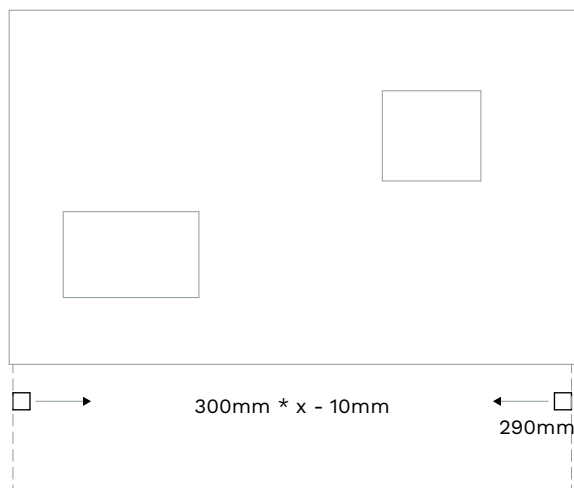

- Start from a corner using a complete tile to achieve a tidy corner.
- Adjust the horizontal seam: 3mm larger or 5mm smaller if necessary. (A seam larger than 10mm is not recommended due to the risk of mice entering the facade.) Vertical seams cannot be changed.

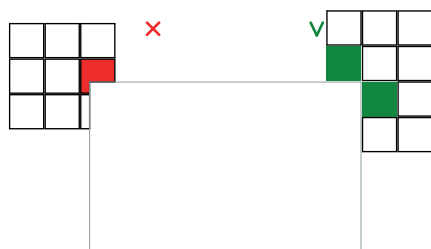

WINDOW CORNERS

Make sure windows are positioned in the same way.

standard seam:
300mm * x - 10mm

larger seam:
301mm * x - 11mm
302mm * x - 12mm
303mm * x - 13mm

smaller seam:
299mm * x - 9mm
298mm * x - 8mm
297mm * x - 7mm
296mm * x - 6mm
295mm * x - 5mm

INSTALLATION MANUAL

PRODUCT NAME SECOND HIGH

PATTERN OPTIONS

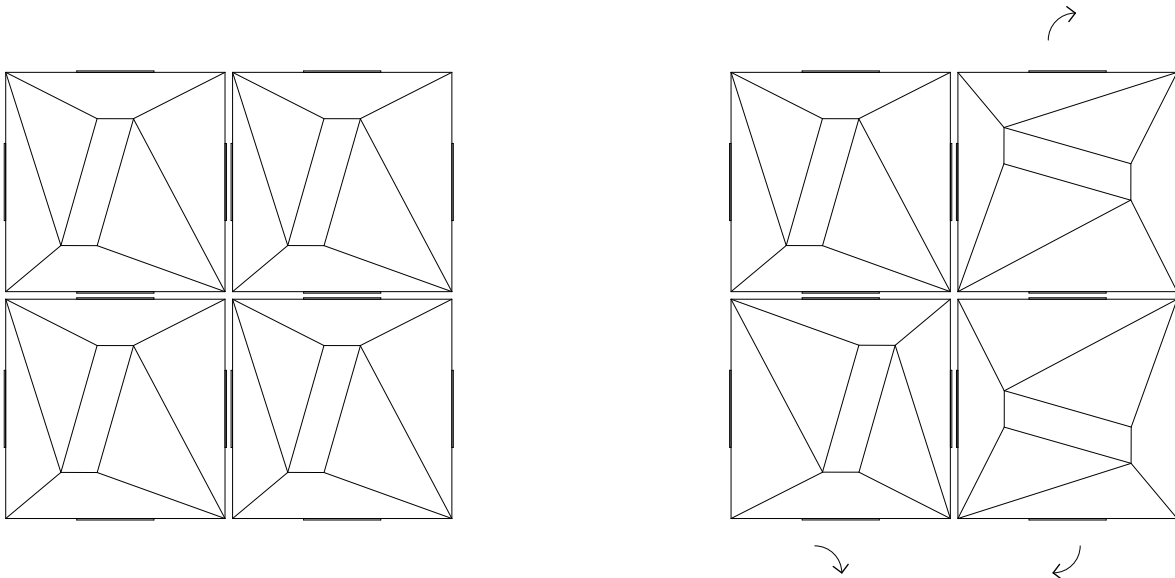

tiles can either all face the same direction or be individually turned to create interesting patterns

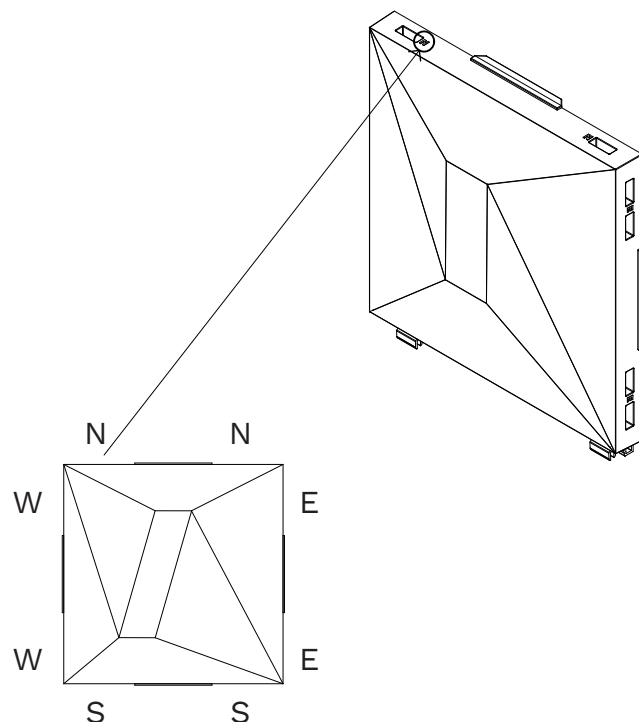

to communicate patterns: marks are made on the site of the tiles

INSTALLATION MANUAL

PRODUCT NAME SECOND HIGH



Pretty
Plastic

building from waste

principle details

INSTALLATION MANUAL

PRODUCT NAME SECOND HIGH

D1 - TOP CONNECTION WINDOW FRAME

SCALE 1:5

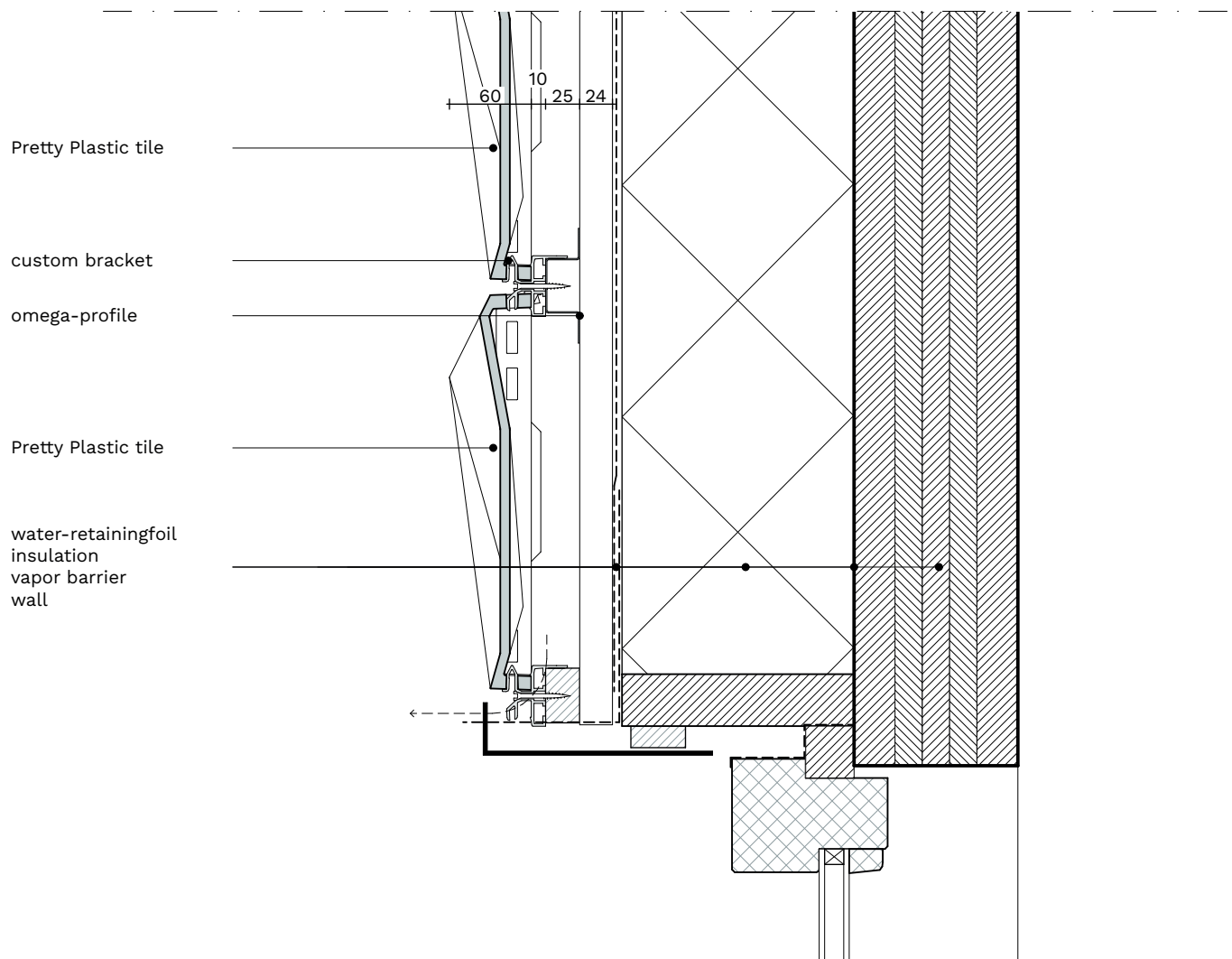

INSTALLATION MANUAL

PRODUCT NAME SECOND HIGH

D2 - BOTTOM CONNECTION WINDOW FRAME

SCALE 1:5

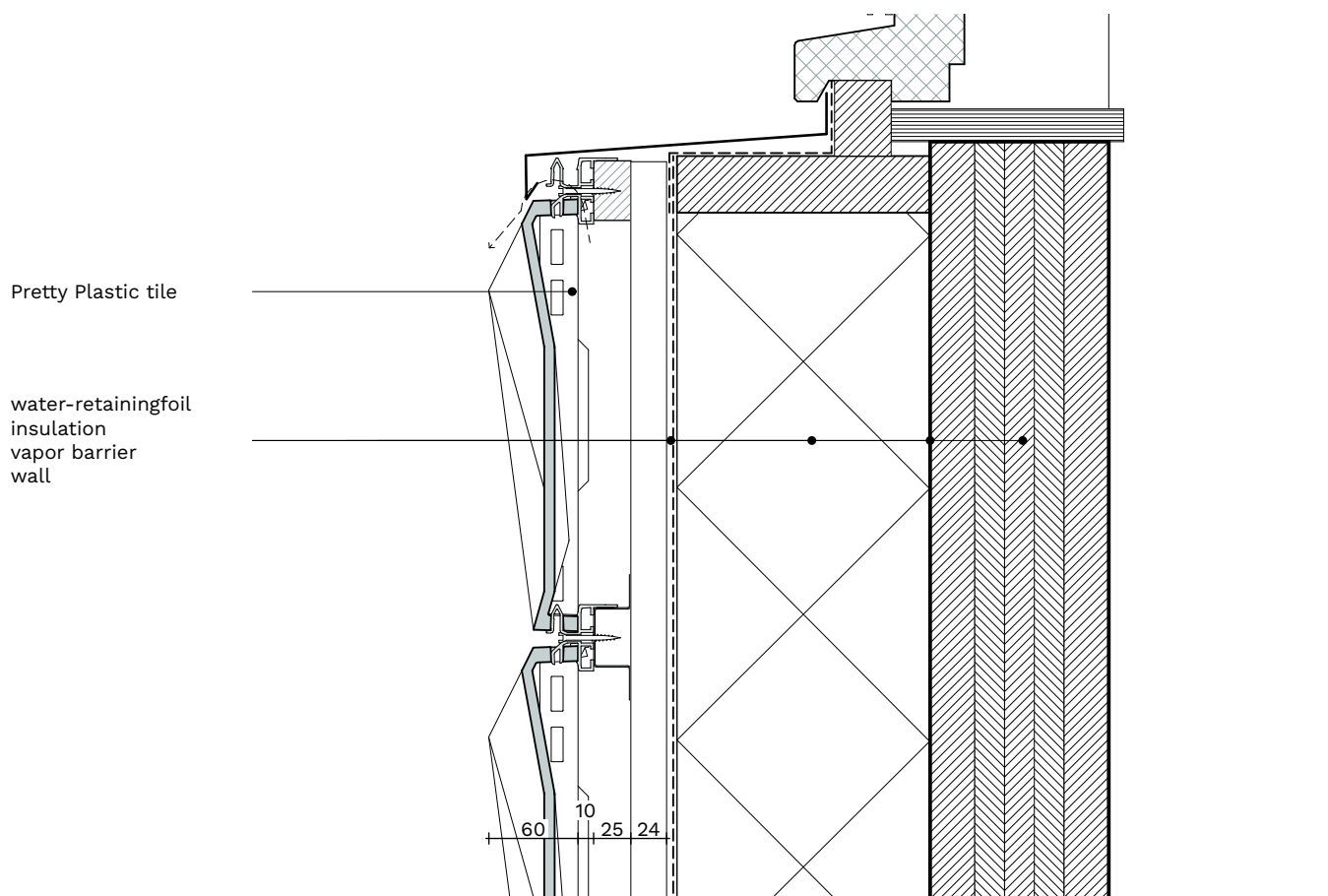

INSTALLATION MANUAL

PRODUCT NAME SECOND HIGH

D3 - WINDOW FRAME HORIZONTAL

SCALE 1:5

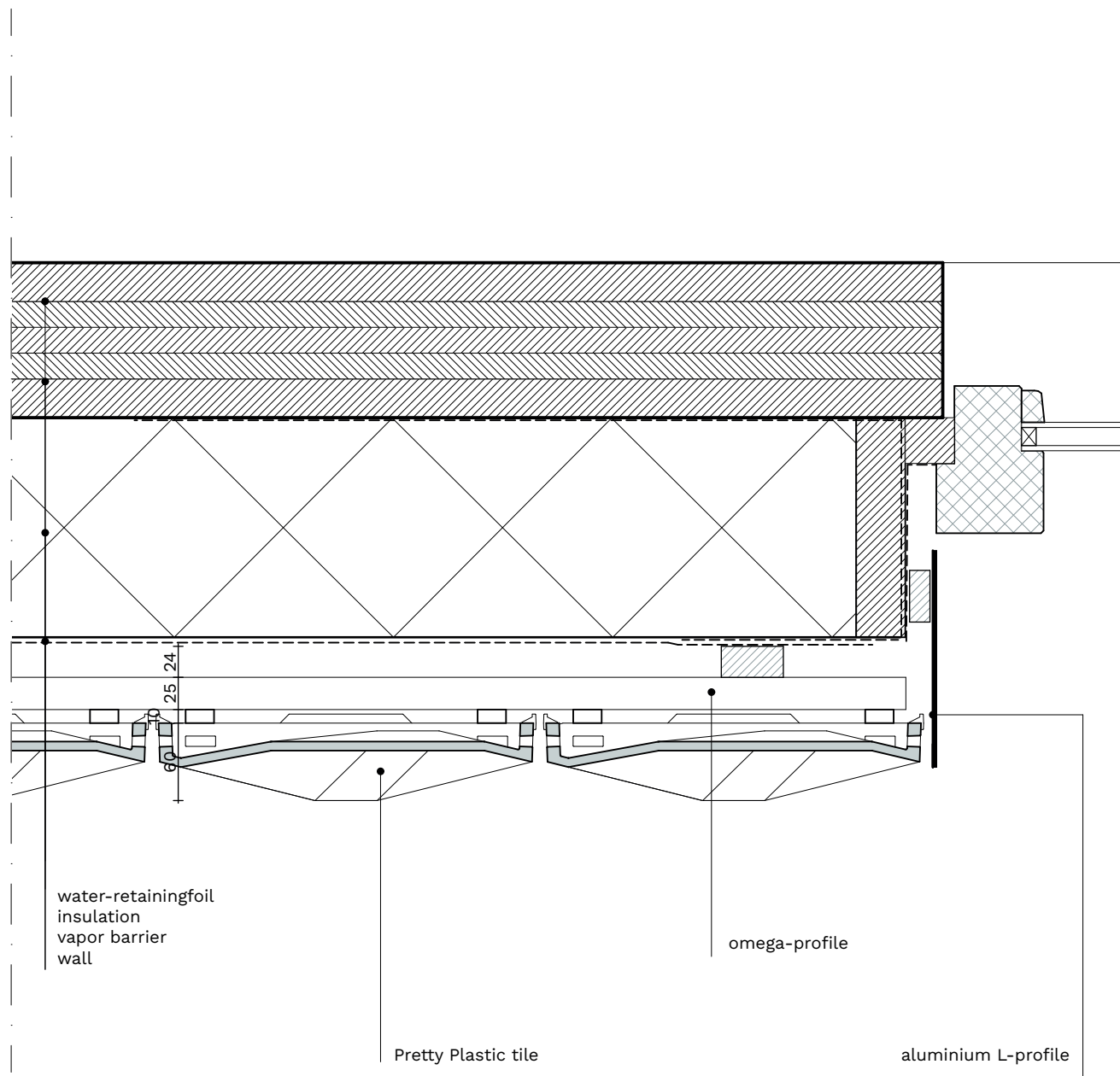

INSTALLATION MANUAL

PRODUCT NAME SECOND HIGH

D4 - CORNER CONNECTION

SCALE 1:5

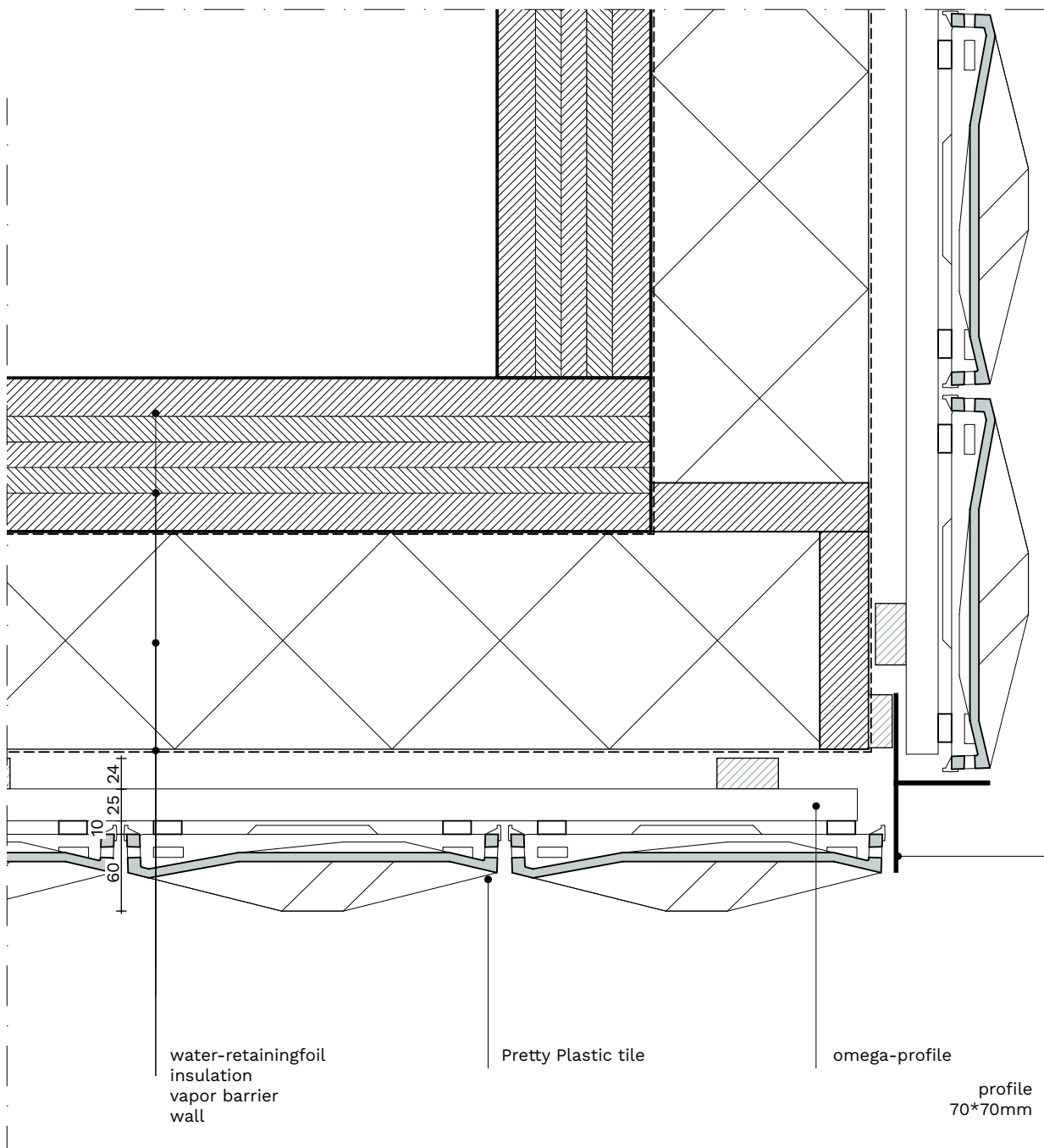

INSTALLATION MANUAL

PRODUCT NAME SECOND HIGH

D5 - CORNER CONNECTION

SCALE 1:5

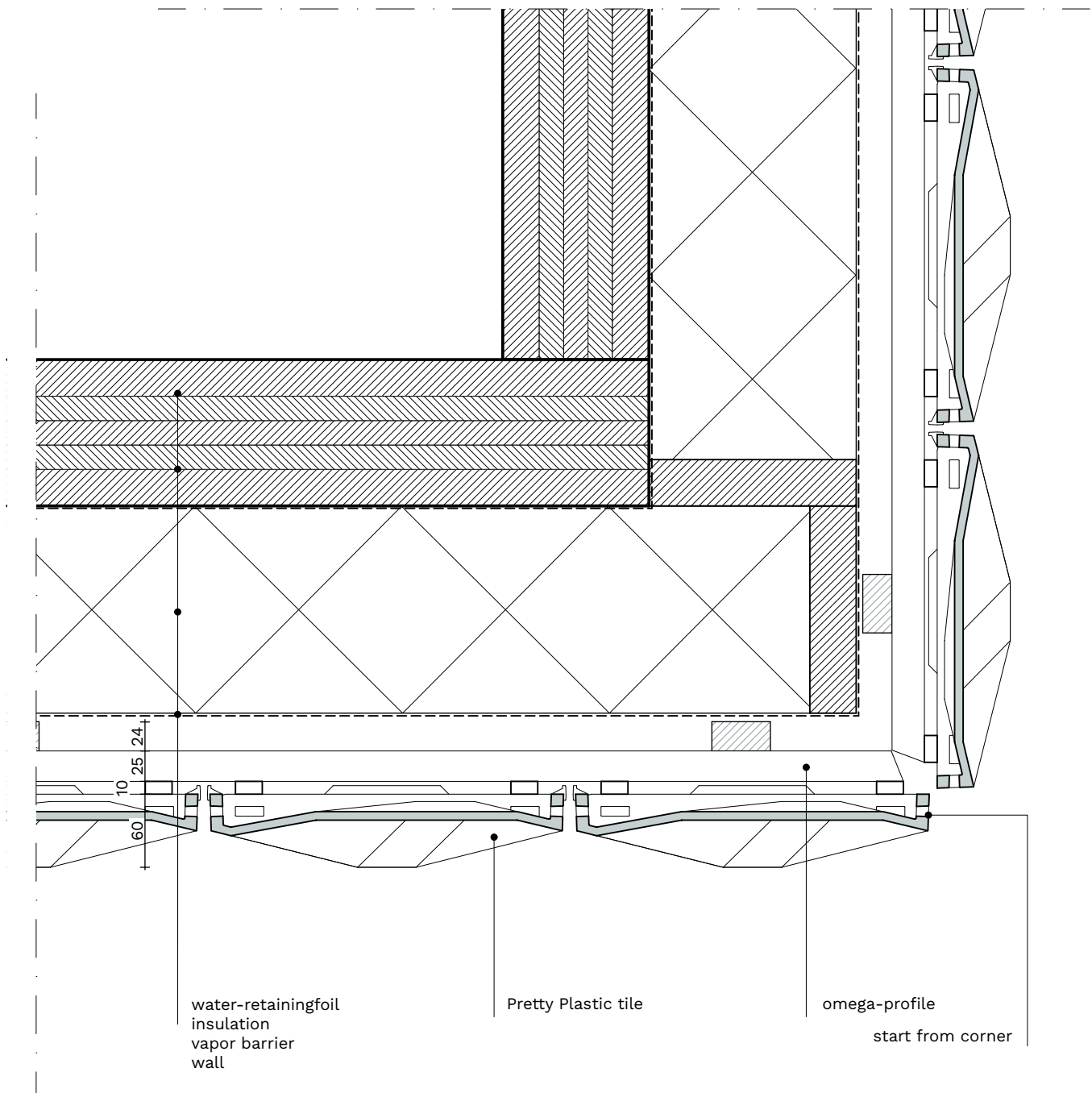

INSTALLATION MANUAL

PRODUCT NAME SECOND HIGH

D6 - CORNER CONNECTION

SCALE 1:5

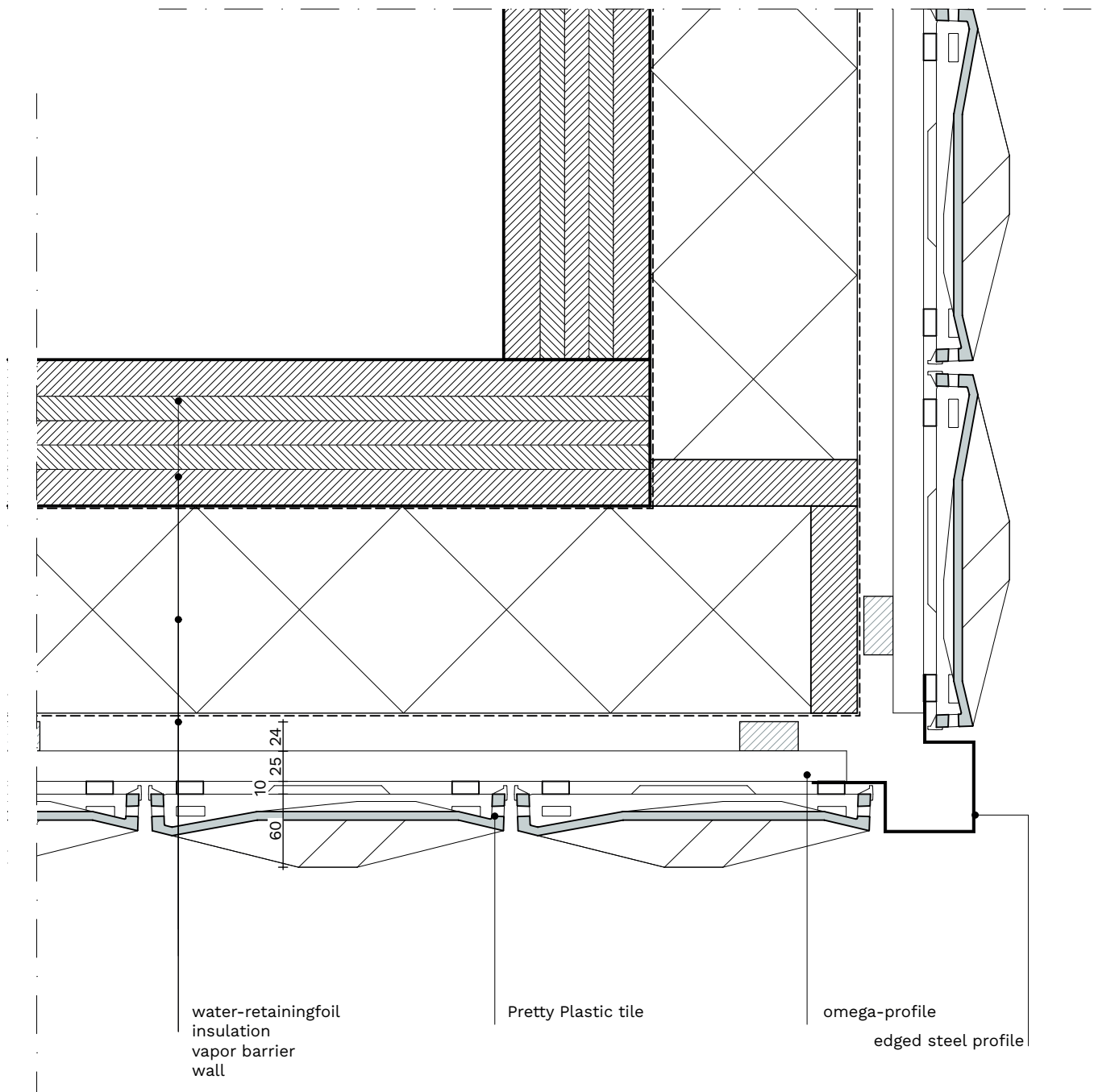

INSTALLATION MANUAL

PRODUCT NAME SECOND HIGH

D7 - CORNER CONNECTION

SCALE 1:5

